

SUBMITTAL RECORD

JOB _____
LOCATION _____
SUBMITTED TO _____
SUBMITTAL PREPARED BY _____
APPROVED BY _____
DATE _____



Submittal Form

FSD-3V-212

Combination Fire / Smoke Damper

**U.L. 555S Classified /
Class II U.L. 555 Classified 1-1/2 Hours
U.L.C. S112 Classified 1-1/2 Hours
Vertical and Horizontal Mountings**

U.L. 555S Classified
at 250°F or 350°F
depending upon Motor/Operator
*See Motor/Operator Schedule



Accepted for use City of New
York
Department of Buildings
MEA#: 302-00-M

Approved by the Board of
Standards and Appeals for use
in New York City
Cal. 291-80-SA

Standard Construction:

Frame: Roll-formed galvanized steel hat-section with staked corners and integral bracing

Blades: 16ga (3V) Roll-formed galvanized steel

Minimum width: 4.250"

Maximum width: 7.250"

Bearings: Bronze Oilite, press-fit into frame

Axles: Square, plated steel

Seals: Pressure sensitive 450°F silicone blade edge seals and flexible metal jamb seals

Linkage: Concealed in frame. Linkage bars are .125" thick plated steel

Heat Responsive Devices: Fusible links - 165°F and 212°F
Heat Sensor - 165°F, 212°F and 350°F

Finish: Mill galvanized

Spring: Stainless steel

Sizes: Minimum size: 6" W x 6" H

Maximum UL Listed size:

Single section: 36" W x 48" H

Multiple assembly:

Vertical: 108" W x 96" H

Horizontal: 72" W x 96" H

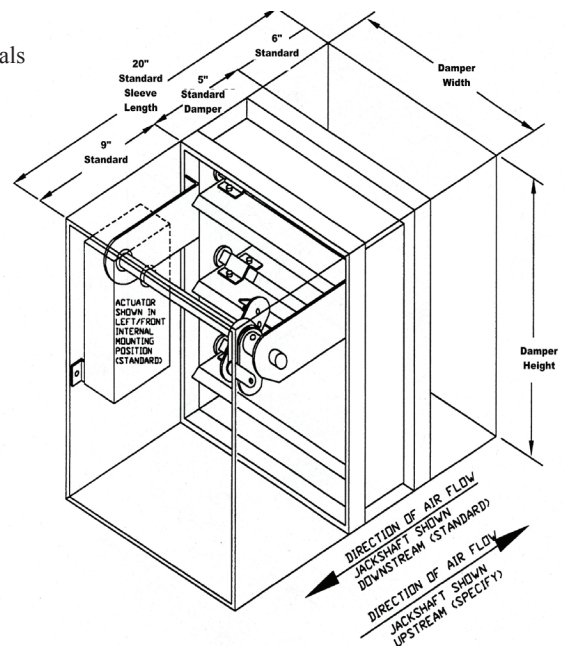

Options:

- Blade Position Indicator Switches
- Electric Heat Sensor STO/R DTO/R
- Sleeves - Duct Gauges with Breakaway connections
- Round Collars

Features:

- The FSD-3V-212 series Combination Fire/Smoke Dampers have been designed and tested to exceed all U.L., U.L.C. and N.F.P.A. requirements for fire dampers as well as to meet or exceed all U.L. (555S) and N.F.P.A. requirements for smoke dampers. They are intended for use where building codes call for the fire damper to also operate as a smoke damper.
- U.L. 555S and U.L.C. S112 listed and labeled as a 1-1/2 hour fire damper.
- U.L. and U.L.C. listed for both vertical and horizontal mountings.
- U.L. 555S listed and labeled as a Leakage Class II rated (smoke) damper with airflow in both directions. Class II provides for a maximum leakage of 10cfm per sq. ft. at 1.0" static pressure. As we are constantly expanding our U.L./U.L.C. listings, we suggest you contact the factory for current information.
- Actuators shaft permits operation by any standard electric or pneumatic damper motor. Flusible link/actuator (DTL-1) provides an automatic override system to close and latch damper in the fire mode. Also available with automatic resettable/override release options: Model STO/R (single thermostat) or Model DTO/R (double thermostat) to provide the fire fighter with complete discretionary control of the smoke functions during a fire/smoke emergency. (See STO/R and DTO/R submittal drawings for complete details.) Spring return type damper motor controlled by a smoke detector is recommended to provide proper operation in the smoke mode.

SUGGESTED SPECIFICATIONS

Combination Fire/Smoke Dampers shall be Duro Dyne FSD-3V-212 type dampers. Fire/Smoke Dampers shall bear the Underwriter's Laboratories labels for both fire dampers and leakage rated (smoke) dampers. U.L. 555S rating shall be Class II with leakage in cfm per sq. ft. not to exceed 20 cfm per sq. ft. at 4.0 inches static pressure for any size. Linkage shall be of the concealed type for a maximum free area.

Duro Dyne National Corporate Headquarters, Bay Shore, NY
631-249-9000 • Fax: 631-249-8346
Duro Dyne Midwest • Duro Dyne West • Duro Dyne Canada
www.durodyne.com • E-mail: durodyne@durodyne.com



11/22/2022